



XCode ® 3106 is a High Performance AVC/MPEG2/4 Transcoder, Decoder and Encoder

- ◇ Transcoding:
 - AVC, MPEG2
 - HD to HD/SD
- ◇ AVC/MPEG2 HD Decoding
- ◇ AVC/MPEG2/4 (ASP, SP) HD/SD Encoding
- ◇ USB 2.0, PCI Express
- ◇ Dual Transport stream Input for ATSC, DVB, and ISDB support
- ◇ Transport stream Output
- ◇ Encryption/Decryption engine

FEATURE SUMMARY

MPEGPerfection™ Encoding

- ◇ AVC HD High Profile up to level 4.1
 - ¼ pixel resolution
 - Full Interlace support – MBAFF
 - Entropy Coding – CABAC/CAVLC
- ◇ MPEG2 up to HD (MP@HL)
- ◇ MPEG4 up to D1 (with PSP, iPOD, DivX™ remux)
 - ASP (L0 – L5)
 - SP (L0 – L3)
- ◇ 525/60 NTSC, 625/50 PAL
- ◇ VBR or CBR encoding
- ◇ Programmable GOP structure
- ◇ 4:2:2 to 4:2:0 conversion
- ◇ Inverse telecine (3:2 pulldown)
- ◇ Scene change detection

Video Decoding

- ◇ MPEG2/AVC HD Decode
 - MPEG2: up to MP@HL
 - AVC: High Profile up to Level 4.1
- ◇ Multi-channel Audio Decoder

Digital Video Filtering

- ◇ Pixel-based motion-adaptive 3D comb filter
- ◇ Pixel-based temporal/spatial filter
- ◇ Image edge rectification

Programmable Audio Processing

- ◇ MPEG2 LI, LII, MP3
- ◇ MPEG2 AAC-LC-Stereo
- ◇ Dolby AC-3 True HD, 7.1, 5.1, Stereo
- ◇ DTS HD, 5.1
- ◇ WMA
- ◇ AMR
- ◇ aacPLUS
- ◇ PCM
- ◇ Others

Smart XCode™ Transcoding/Transrating

- ◇ Format conversion of multiple streams (SD/HD):
 - AVC >> MPEG2, MPEG4 (ASP, SP), AVC
 - MPEG2 >> AVC, MPEG2, MPEG4 (ASP, SP)
- ◇ Bit-rate reduction of multiple streams:
 - 40 Mbps >> 64 Kbps
- ◇ Resolution reduction of streams:
 - HDTV >> HDTV >> SDTV >> CIF >> QCIF
- ◇ High-speed video processing 2X – 12X real-time

Stream Formats Supported (In/Out)

- ◇ Elementary Stream (ES), Packetized Elementary Stream (PES), Program Stream, Transport Stream (TS)
- ◇ YUV in/out stream support via PCI

INTERFACES

- ◇ Transport stream inputs (up to 2 serial)
- ◇ Transport stream output
 - i. Re-multiplexor
- ◇ DDR2 SDRAM memory controller
- ◇ PCI Express
- ◇ I²C – master/slave
- ◇ 1 x 8/10 bit CCIR 656 input
- ◇ 1 x I²S inputs
- ◇ 1x UART
- ◇ 1x USB 2.0
- ◇ SPDIF In
- ◇ SPI EEPROM interface for booting
- ◇ General Purpose I/O

SECURITY FEATURES

- ◇ Supports capture and descrambling of ATSC, DVB, and ISDB-T protected standards
- ◇ Supports DVB/DES/3DES/Multi2/3DES descrambling
- ◇ Supports multiple digital right management schemes i.e. MSDRM, RealNetworks, DTCP/IP, etc. with a powerful encryption/decryption engine

TECHNOLOGY

- ◇ Efficient Low Power Design
- ◇ 90 nm CMOS design
- ◇ 19mm x 19mm BGA package

TYPICAL APPLICATIONS

- ◇ IPTV, Cable, and Satellite Set-Top boxes
- ◇ Personal Video Recorders (PVR's)
- ◇ DTV, PVR DTV
- ◇ Blu Ray Recorder/Player
- ◇ DTV PVR
- ◇ Residential / Home Gateways
- ◇ Video NAS

CORE TECHNOLOGIES

- ◇ Smart XCode™ technology allows users to convert formats, resolution, and frame rates of pre-compressed video, up to 12X faster than real-time, to fit video to many viewing devices
- ◇ MPEGPerfection™ technology defining low-bitrate HD compression without compromising video quality

XCode® 3106 BLOCK DIAGRAM

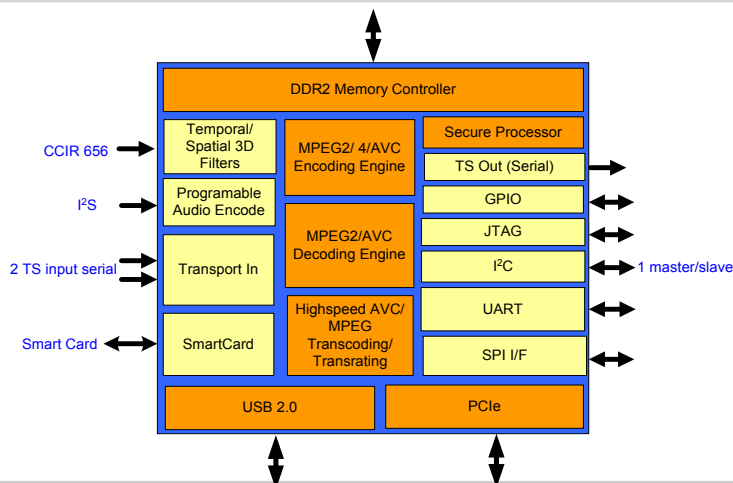

TRANSCODER APPLICATIONS

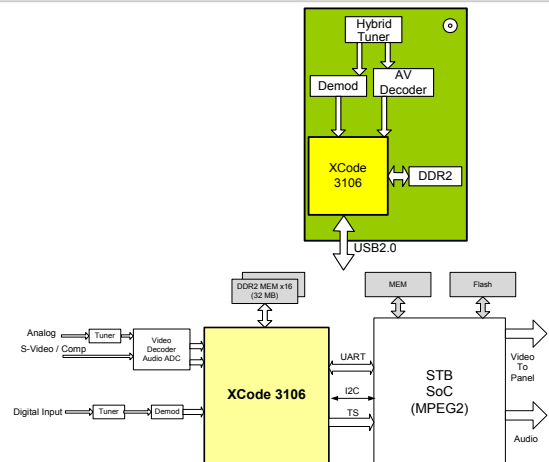

ViXS Systems, Inc.
 1210 Sheppard Ave East, Suite 800
 Toronto, ON, Canada, M2K 1E3

Phone: (416) 646-2000
 Fax: (416) 646-1042
 Web: www.vixs.com